

4

3

2

1

THIS DRAWING IS UNPUBLISHED. RELEASED FOR PUBLICATION ,19 .
 © COPYRIGHT 19 BY AMP INCORPORATED. ALL RIGHTS RESERVED.

LOC		DIST		REVISIONS			
P	LTR	DESCRIPTION		DATE	DWN	APVD	
G	14	E		REDRAWN PER 0720-0470-95	23JAN95	LO ME	

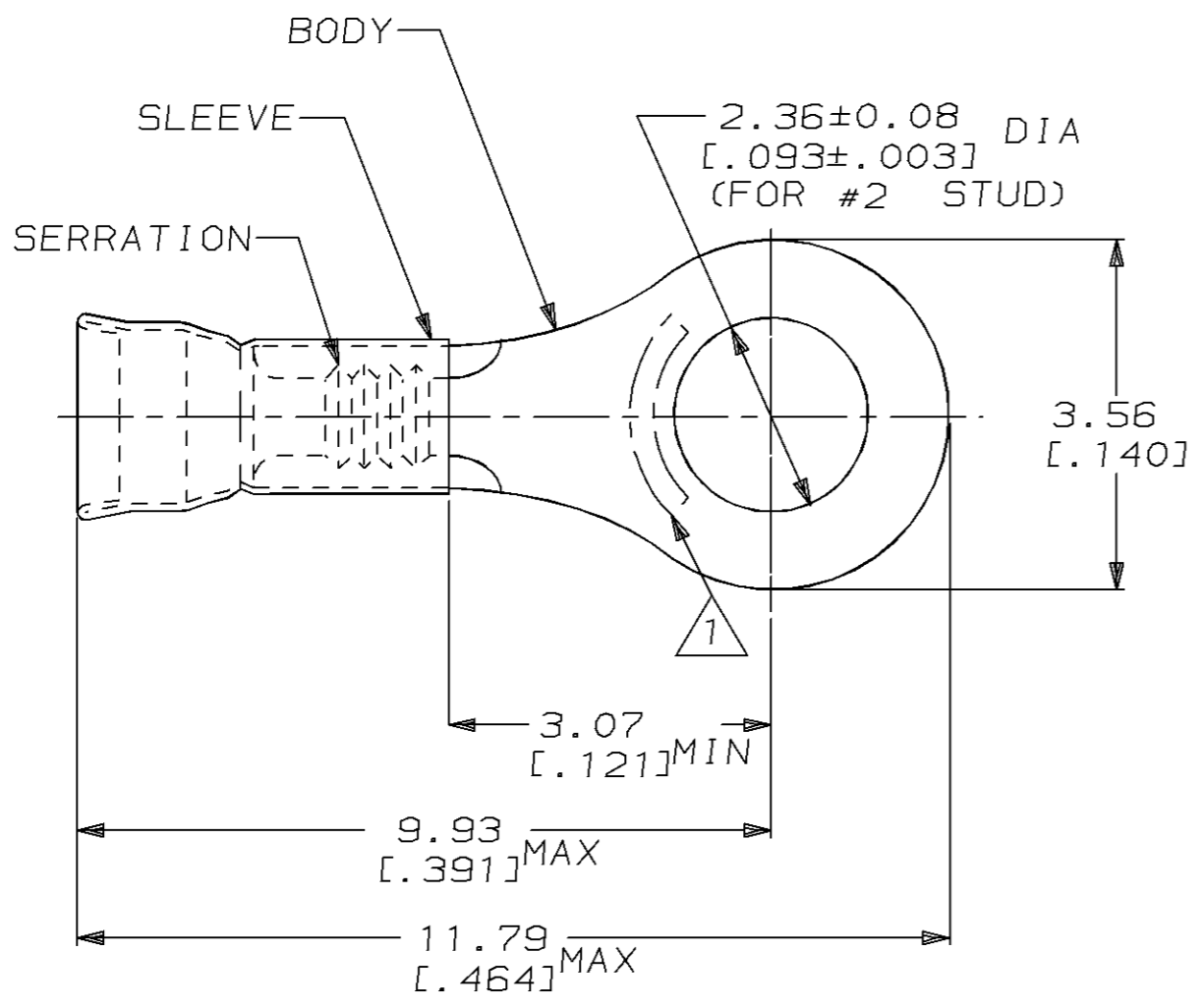

△ STAMP AMP LOCATE APPROX AS SHOWN

- 2. WIRE INSUL DIA, 1.27-2.08 [.050-.082]
- 3. TONGUE MATL THK, 0.46±0.05 [.018±.002]

5000	ON TAPE, REEL	2-31518-1
1000	LOOSE PIECE	31518
QTY	PACKAGE TYPE	PART NO

AMP INCORPORATED
 CUSTOMER SERVICE SYSTEM

FOR ADDITIONAL PRODUCT INFORMATION OR COPIES OF DRAWINGS AND TECHNICAL DOCUMENTS
 PRODUCT INFORMATION CENTER
 1-800-522-6752

FOR APPLICATION TOOLING INFORMATION
 TOOLING ASSISTANCE CENTER
 1-800-722-1111

FOR ORDER ENTRY
 1-800-526-5142

MAX RECOMMENDED OPERATING TEMPERATURE:
 -

VOLTAGE RATING:
 -

CIRCULAR MIL AREA:
 0.10mm²-0.41mm² [202-810]

STRANDED WIRE

THIS DRAWING IS A CONTROLLED DOCUMENT FOR AMP INCORPORATED. IT IS SUBJECT TO CHANGE AND THE CONTROLLING ENGINEERING ORGANIZATION SHOULD BE CONTACTED FOR THE LATEST REVISION.

DIMENSIONS: mm [in]

TOLERANCES UNLESS OTHERWISE SPECIFIED:

0 PLC	±-
1 PLC	±-
2 PLC	±0.20 [.008]
3 PLC	±-
4 PLC	±-
ANGLES	±-

MATERIAL: BODY, CU, SLV, CU PER ASTM B152

FINISH: TIN PLATE PER MIL-T-10727

DWN L OLMEDA 23JAN95
 CHK M ELLIS 23JAN95
 APVD S BORTNER 23JAN95

PRODUCT SPEC
 -

APPLICATION SPEC
 -

WEIGHT -

CUSTOMER DRAWING

AMP AMP Incorporated
 Harrisburg, PA 17105-3608

NAME: TERMINAL, RING, DIAMOND GRIP, WIRE SIZE, 26-22 AWG

SIZE: A3 CAGE CODE: 00779 DRAWING NO: C-31518

SCALE: 10:1 SHEET: 1 OF 1 REV: E